

Products

Ball Valve 430

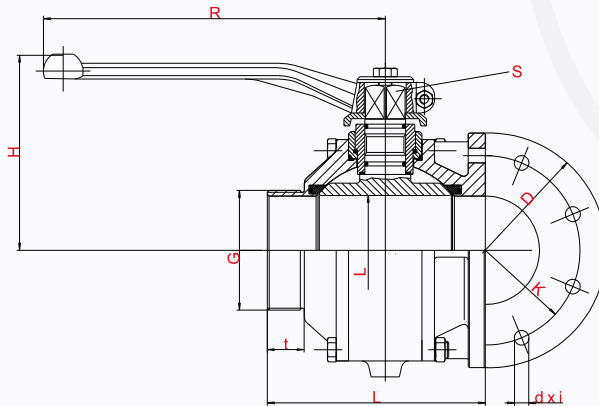

PROVEN & RELIABLE
FOR USE IN:

INDUSTRIAL

FUEL HANDLING

BULK HANDLING

TANK TRUCK CONSTR.

SILO TRUCK CONSTR.

PROKOSCH Ball Valve for Tank Trucks No. 430

Side one flange per DIN 28480, side two male pipe thread per DIN 259

Prokosch 430-series ball valves use fewer individual parts, have space-saving elements, are based on a practical modular principle and are easy to switch. The free cylindrical pass reduces flow resistance to a minimum and the dual-sided bearing configuration of the ball ensures a uniformly low switching torque throughout the entire pressure region.

- ▶ Nominal size 50 to 100 available in all material combinations.
- ▶ "PTFE/special casing" design with self-adjusting seal system for a permanent fitting seal. Particularly suitable for fluids such as mineral oils. Standard production O-rings made of FPM or lower priced buna-N.
- ▶ "PTFE/O-ring spring-mounted" design with strong seal system, developed specifically for use with powdered and granular goods.
- ▶ "Stainless steel/O-ring spring-mounted" design with metallic seal system for a long tool life when using abrasive materials.
- ▶ Standard design with manual lever. "SO" design set up for automation.
- ▶ "FA" design with aerodynamic jam-free discharge flange for use with media that easily clog the fitting.
- ▶ Special designs regarding material and design are available upon request.

Nom. width DN	LW	Nom. press. PN	Dimensions										Approx. weight (kg)			
			L	D	K	dxi	t	H	R	G	SW	5	3,4	1,2,6,7,10	8,9	
50 2"	50	10	140	154	130	11,5x8	20	130	250	R2"	17	2,9	3,7	6,7	3,9	
65 2 1/2"	64	10	158	154	130	11,5x8	20	140	270	R2 1/2"	19	4,5	6,0	9,9	6,4	
80 3"	78	10	160	154	130	11,5x8	24	150	270	R3"	19	5,2	7,3	12,5	7,9	
100 4"	97	10	195	174	150	14,0x8	25	175	330	R4"	27	8,9	13,3	22,3	14,2	